

IXA-05N 拉杆型电动缸 Rod type electric actuator

本体宽幅54mm Actuator width 54mm

滚珠丝杠驱动型
Ball screw driven

型号 Model	IXA-05N	①	②	③	④	⑤	⑥	⑦
类别 Series	宽幅 Width	导程 Lead	行程 Stroke	马达安装样式 Motor position	精度等级 Precision	感应开关 Sensor	马达规格 Motor Spec.	特殊选项 Options
		P05: 5mm P10: 10mm P20: 20mm	50: 50mm ~ 600: 600mm (50mm间隔) (50mm increment)	1K: 马达直连外露型 Motor exposed 2L: 马达左折 Motor left side 2R: 马达右折 Motor right side 3: 马达下折 Motor bottom side	C: 普通级 Standard	J: 三组, 外挂式左侧 3 sets, Outside left K: 三组, 外挂式右侧 3 sets, Outside right N: 无 None	□01□: 100W伺服马达 100W Servo motor (马达代号含义请参见K003页) (Motor code refer to K003)	Z: 电机客户自备 Motor provided by customers

通用规格 Common Specifications

重复定位精度 Positioning repeatability	±0.01mm
驱动方式 Drive method	Φ12mm转造C7级 ballscrew Φ12mm Rolled C7
拉杆不旋转精度 Rod anti-rotating accuracy	0°
感应器 Sensors	CS-6T, NPN, 24V DC
基座材质 Base material	挤压铝型材, 白色光泽 Aluminum, white
安装面精度要求 Mounting plate flatness	平面度0.05mm以下 flatness 0.05mm max.
使用环境 Ambient operating temperature/humidity	0~40°C, 85%RH(无凝结 non-condensing)



技术参数 Specification

AC伺服电机功率 AC Servo Motor Output (W)	100		
额定扭矩 Rated Torque (N·m)	0.32		
滚珠丝杠导程 Ballscrew Lead (mm)	5	10	20
最高速度 Maximum Speed (mm/sec)	250	500	1000
额定加速度 Rated Acceleration (mm/sec ²) (※1)	0.3G	0.3G	0.3G
最大可搬重量(kg) (※2) Maximum Payload	水平 Horizontal	30	15
	垂直 Vertical	10	5
额定推力 Rated Thrust (N)	361.7	180.9	90.5
行程范围 Stroke (mm)	50~600 (50间隔 50 increment)		
马达额定转速 Rated speed of motor (RPM)	3000		

注1 Note 1: 1G=9800mm/sec²。注2 Note 2: 此负荷需要安装外部导轨承受径向负载。

出力轴变形量

Shaft output deformation value

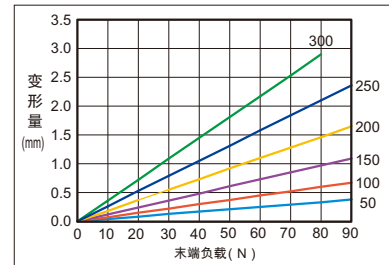

注: 此表格为参考值。

感应器接线图

Sensor layout

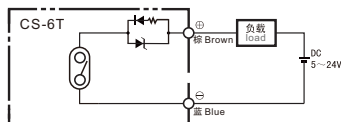

一般性负载: 继电器或其他电阻性负载
General load: such as relay or other resistive load

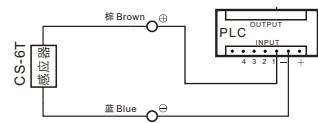

可编程控制器接线图
PLC connection diagram

允许安装负载

Allowable installation load

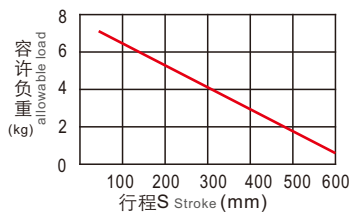
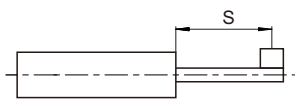

无外部辅助导轨机构, 负载无延伸距离。

垂直允许负载

Overhang and allowable load

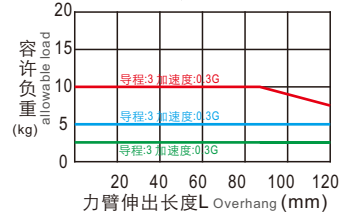
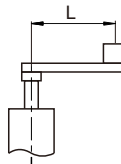

常用电机品牌及规格 Suitable Motor Brand

电机品牌 Brand	电机功率 Output	电机标记 Mark	制动器 Brake	电源电压 AC-Voltage	伺服电机型号 Motor Model	伺服驱动器型号 Driver Model	控制方式 Control Type	线缆配置 Cables
松下 Panasonic	100 W	P01	无制动器(水平安装) No brake (Horizontal)	220 V	MSMF012L1U	MADLN05SE	脉冲型 Pulse type	3M/5M
		P01B	有制动器(垂直安装) With brake (Vertical)	220 V	MSMF012L1V	MADLN05SE	脉冲型 Pulse type	3M/5M
三菱 Mitsubishi	100 W	M01	无制动器(水平安装) No brake (Horizontal)	220V	HG-KN13J-S100	MR-JE-10A	脉冲型 Pulse type	3M/5M
		M01B	有制动器(垂直安装) With brake (Vertical)	220V	HG-KN13BJ-S100	MR-JE-10A	脉冲型 Pulse type	3M/5M

※: 选用非上述品牌电机时, 客户需提供电机的规格和安装尺寸图。

IXA-05N 拉杆型电动缸 Rod type electric actuator

本体宽幅54mm Actuator width 54mm

滚珠丝杠驱动型
Ballscrew driven

拉杆型电动缸

外型尺寸图 Diagram

1K 马达外露型 Motor exposed

2D/3D CAD
www.sz-vinko.com

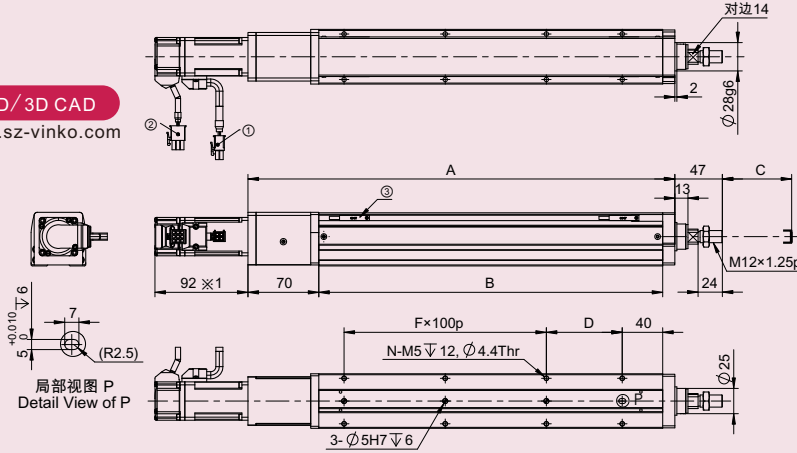

HOME:原点
S.E.:行程末端 Stroke End
M.E.:机械末端 Mechanical End
①:电机用连接器 Motor connector
②:编码器用连接器 Encoder connector
③:感应器 Sensors

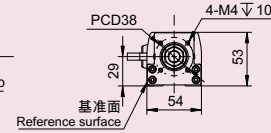

注意 CAUTION:
※1: 标配电机为松下A6系列100W伺服电机。带制动器时电机长度为122mm。
Default servo motor model: MSMF012L1U2 (100W, panasonic A6 series). When with brake, the length of motor body is 122mm. (MSMF012L1V2)

尺寸图代号说明 · 质量 Dimensions, Mass

单位Unit: mm

有效行程 Stroke	50	100	150	200	250	300	350	400	450	500	550	600
A	272	322	372	422	472	522	572	622	672	722	772	822
B	190	240	290	340	390	440	490	540	590	640	690	740
C	50	100	150	200	250	300	350	400	450	500	550	600
D	25	75	25	75	25	75	25	75	25	75	25	75
F	1	1	2	2	3	3	4	4	5	5	6	6
N	6	6	8	8	10	10	12	12	14	14	16	16
质量 Mass(kg)	1.8	2.2	2.6	3	3.4	3.8	4.2	4.6	5	5.4	5.8	6.2

注1: 重量不含马达。 Note 1: The motor mass is not included.

外型尺寸图 Diagram

2L 马达左折 Motor left side

2D/3D CAD
www.sz-vinko.com

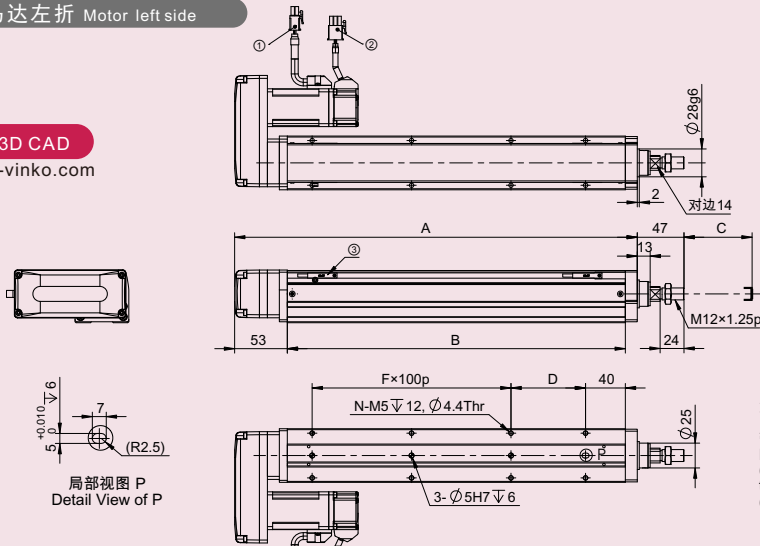

HOME:原点
S.E.:行程末端 Stroke End
M.E.:机械末端 Mechanical End
①:电机用连接器 Motor connector
②:编码器用连接器 Encoder connector
③:感应器 Sensors

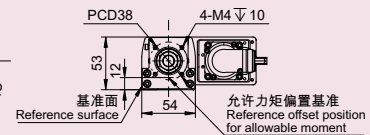

注意 CAUTION:
※1: 标配电机为松下A6系列100W伺服电机。带制动器时电机长度为122mm。
Default servo motor model: MSMF012L1U2 (100W, panasonic A6 series). When with brake, the length of motor body is 122mm. (MSMF012L1V2)

尺寸图代号说明 · 质量 Dimensions, Mass

单位Unit: mm

有效行程 Stroke	50	100	150	200	250	300	350	400	450	500	550	600
A	255	305	355	405	455	505	555	605	655	705	755	805
B	190	240	290	340	390	440	490	540	590	640	690	740
C	50	100	150	200	250	300	350	400	450	500	550	600
D	25	75	25	75	25	75	25	75	25	75	25	75
F	1	1	2	2	3	3	4	4	5	5	6	6
N	6	6	8	8	10	10	12	12	14	14	16	16
质量 Mass(kg)	1.7	2.1	2.5	2.9	3.3	3.7	4.1	4.5	4.9	5.3	5.7	6.1

注1: 重量不含马达。 Note 1: The motor mass is not included.

IXA-05N 拉杆型电动缸 Rod type electric actuator

本体宽幅54mm Actuator width 54mm

滚珠丝杠驱动型
Ballscrew driven

外型尺寸图 Diagram

2R 马达右折 Motor right side

2D/3D CAD
www.szvinko.com

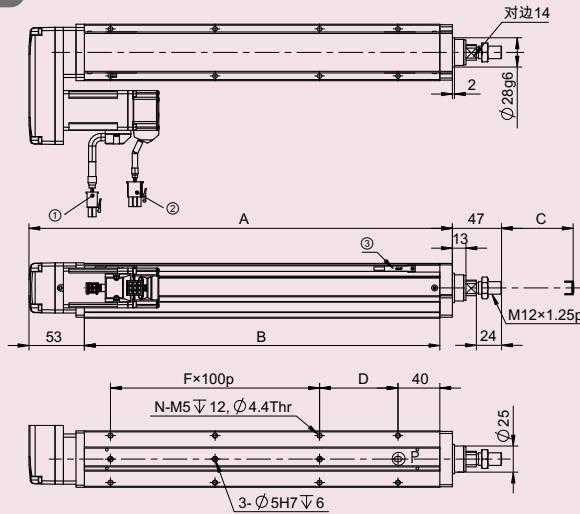
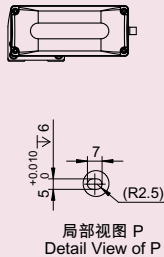

HOME:原点
S.E.:行程末端 Stroke End
M.E.:机械末端 Mechanical End
①: 电机用连接器 Motor connector
②: 编码器用连接器 Encoder connector
③: 感应器 Sensors

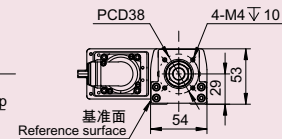

注意 CAUTION:
※1: 标配电机为松下A6系列100W伺服电机。带制动器时电机长度为122mm。
Default servo motor model: MSMF012L1U2 (100W, panasonic A6 series). When with brake, the length of motor body is 122mm. (MSMF012L1V2)

尺寸图代号说明 · 质量 Dimensions, Mass

单位Unit: mm

有效行程 Stroke	50	100	150	200	250	300	350	400	450	500	550	600
A	255	305	355	405	455	505	555	605	655	705	755	805
B	190	240	290	340	390	440	490	540	590	640	690	740
C	50	100	150	200	250	300	350	400	450	500	550	600
D	25	75	25	75	25	75	25	75	25	75	25	75
F	1	1	2	2	3	3	4	4	5	5	6	6
N	6	6	8	8	10	10	12	12	14	14	16	16
质量 Mass(kg)	1.7	2.1	2.5	2.9	3.3	3.7	4.1	4.5	4.9	5.3	5.7	6.1

注1: 重量不含马达。 Note 1: The motor mass is not included.

外型尺寸图 Diagram

3 马达下折 Motor bottom side

2D/3D CAD
www.szvinko.com

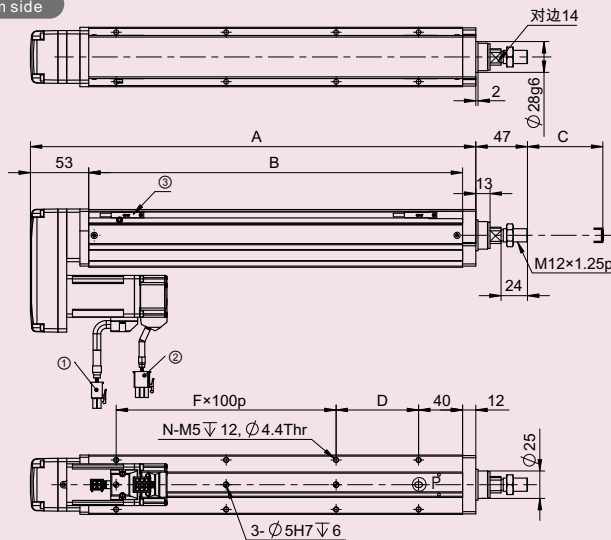
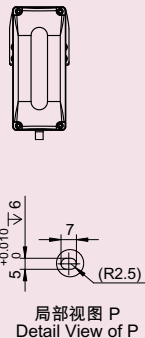

HOME:原点
S.E.:行程末端 Stroke End
M.E.:机械末端 Mechanical End
①: 电机用连接器 Motor connector
②: 编码器用连接器 Encoder connector
③: 感应器 Sensors

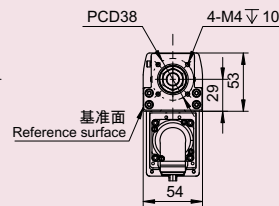

注意 CAUTION:
※1: 标配电机为松下A6系列100W伺服电机。带制动器时电机长度为122mm。
Default servo motor model: MSMF012L1U2 (100W, panasonic A6 series). When with brake, the length of motor body is 122mm. (MSMF012L1V2)

尺寸图代号说明 · 质量 Dimensions, Mass

单位Unit: mm

有效行程 Stroke	50	100	150	200	250	300	350	400	450	500	550	600
A	255	305	355	405	455	505	555	605	655	705	755	805
B	190	240	290	340	390	440	490	540	590	640	690	740
C	50	100	150	200	250	300	350	400	450	500	550	600
D	25	75	25	75	25	75	25	75	25	75	25	75
F	1	1	2	2	3	3	4	4	5	5	6	6
N	6	6	8	8	10	10	12	12	14	14	16	16
质量 Mass(kg)	1.7	2.1	2.5	2.9	3.3	3.7	4.1	4.5	4.9	5.3	5.7	6.1

注1: 重量不含马达。 Note 1: The motor mass is not included.

选型指南

IK系列
单轴机器人IX系列
单轴机器人BS系列
单轴机器人BSC系列
单轴机器人TSN系列
单轴机器人TSC系列
单轴机器人IRV2/IRV3系列
直交机器人RC系列
机器人控制器

参考资料

IXA-04N

IXA-05N

IXA-08N

IXA-05N 拉杆型电动缸

Rod type electric actuator
本体宽幅54mm Actuator width 54 mm

滚珠丝杠驱动型
Ball screw driven

拉杆型电动缸

MEMO

IXA-04N

IXA-05N

IXA-08N

2D/3D CAD

可通过如下方式获取：
2D/3D CAD data can be available by:



<https://vinko.partcommunity.com>

技术支持：德国卡第那思公司
CADENAS Technologies AG



<http://www.sz-vinko.com>

VINKO 2D/3D CAD数据官网下载网址：
<http://www.sz-vinko.com/download/cad.html>